

The 2nd International Theater Festival

A World Class AACT

June 22 - 26, 1994
Racine, Wisconsin U.S.A.



Together Again

Official Proclamation

OFFICE OF THE MAYOR
CITY OF RACINE, WISCONSIN

Whereas:

The Racine Theatre Guild and the American Association of Community Theaters (AACT) are presenting the second International AACT - Fest during the week of June 22-26, 1994; and

WHEREAS, theatre companies from all over the world are coming together to share in the joy of the theater through competition, friendship and the love of the arts; and

WHEREAS, this unique celebration will assemble several foreign theater companies, international adjudicators and exciting workshops with nationally and internationally known theater professionals; and

WHEREAS, the AACT II celebration includes home-hosted dinners, opening ceremonies featuring a Native American dance company, award ceremonies, receptions, lunches, a festival gala and excursions to local attractions; and

WHEREAS, social events will reflect the international theme of the festival by highlighting the customs and traditions of participating international companies.

NOW, THEREFORE, I, N. OWEN DAVIES, Mayor of the City of Racine, do hereby extend a warm welcome to all visitors and participants in this gala event and wish them an enjoyable stay and a successful celebration.

IN WITNESS WHEREOF, I have hereunto set my hand and caused the Seal of the City of Racine to be affixed.



Done at the City Hall
this 21 day of Jun, 1994.

N. Owen Davies
N. Owen Davies, Mayor

FESTIVAL SPONSORS



Twin Disc
Firstar Bank
Wisconsin Electric & Power

Walter S. Smolenski, Jr. and Sr. Polish History and Culture Fund within the Racine Community Foundation

Supported in part by a grant from the Wisconsin Arts Board with funds from the State of Wisconsin.



Official Proclamation

by the County Executive
of Racine County, Wisconsin

Whereas: the Racine Theatre Guild and the American Association of Community Theaters are hosting an international festival of community theater groups; and

WHEREAS, this festival, known as AACT II (2nd International AACT-Fest), will bring together community theater groups from North and South America, Europe, Asia and Africa; and

WHEREAS, visitors to the festival will be able to attend productions from Canada, Colombia, Denmark, England, France, Germany, Italy, Japan, Poland, Spain, Ghana and the United States; and

WHEREAS, Racine County is honored to host the Festival and its participants and to have the opportunity to showcase our community, our citizens and the activities and facilities of which we are so justly proud;

NOW THEREFORE, I, Dennis Korymball, County Executive, Racine County, do hereby proclaim Wednesday, June 22 through Sunday, June 26, 1994 as

"AACT-FEST DAYS"

in Racine County, and call upon our citizens to welcome all the theater groups which have come to Racine to participate in the Festival as well as all those people who have come to attend the productions and workshops and to wish them all a wonderful experience at the festival and in our community.

IN WITNESS WHEREOF, I have hereunto set my hand and caused the Seal of the County Executive of Racine County to be affixed.

Signed at the Courthouse

this 21 day of June, 1994
at Racine, Wisconsin

Dennis Korymball
Dennis Korymball
Racine County Executive



WELCOME

We welcome you, on behalf of the Racine Theatre Guild to enjoy this second International AACT Festival. This is a grand occasion for all of us and the City of Racine. We are honored to have you here as our guests.

It takes many people putting forth tremendous effort to stage a festival of this magnitude. Planning for this event began 18 months ago with a small executive committee of eight. In only weeks, willing and talented volunteers joined committees and began to work on tasks of fund raising, publicity, housing, transportation, food, scheduling performances, workshops, rehearsals and entertainment, registration and recordkeeping, security and health insurance for our performers. Everyone worked in concert to provide for you the festival you now experience.

A most sincere thanks to the theater companies for making their long trek to Racine. We know commitment to the art of theater and the pleasure of performing are the essential fuels which powered their journey.

Even with all of these efforts, the festival would not have been possible without the generous donations of local businesses, organizations and individuals. We hope you enjoy this unique opportunity to see the best in community theater from around the world combined with the warm hospitality of Racine.



Stan Sutherland
Festival Co-Chair

Dawn Sutherland
Festival Co-Chair

"Now who will stand on either hand, and keep the bridge with me?"

Macbeth – William Shakespeare

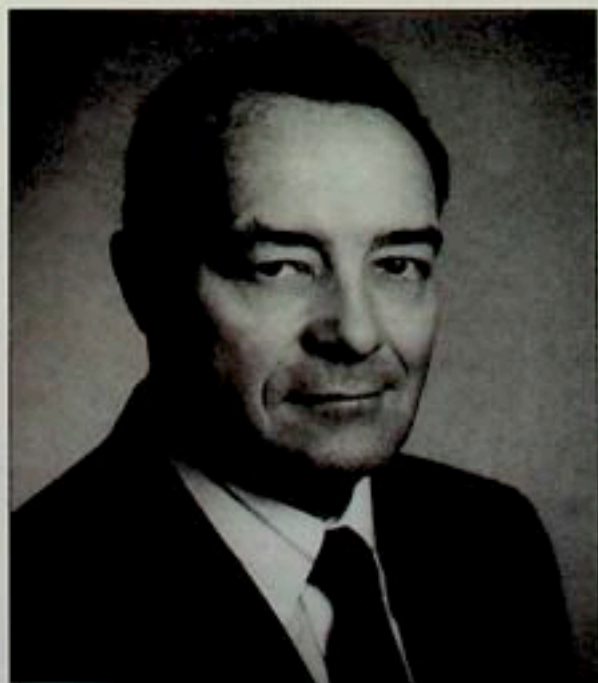

You may wonder how bridges can be tied into an International Theatre Festival.

Since 1979 Racine Theatre Guild has developed an international focus; however, it was in 1987 at a festival in Utrecht, the Netherlands, that the higher purpose of festivals was revealed. The theme of The Utrecht festival was "Bridges," like the bridges that connect the canals in Utrecht linking parts of the city together. Similarly, bridges connect various peoples to one another, bridges connect one culture to another, and bridges connect us together throughout the world. Since theatre has always been a celebration of what it means to be human, then through the bridges to our various cultures we can understand that the same things make all of us laugh, cry, dance, and feel human emotions. Our microcosm of theatre devotees represents all the highest ideals of human kind and our ability to reach out to one another. It is with great pride that we "build our bridge" from Racine Theatre Guild to all of you – registrants, participants, volunteers, guests, and audience members. Thanks to everyone who has helped build this bridge.

Now, "Let the Plays Begin!"

Norman C. McPhee
Managing/Artistic Director
Racine Theatre Guild

AACT II SCHEDULE OF EVENTS

Wednesday June 22, 1994

10:00 a.m. - 4:00 p.m.	AACT Full Board Meeting	Holiday Inn
9:00 a.m. - 4:30 p.m.	Registration	Racine Theatre Guild
1:00 - 3:00 p.m.	Workshop - Scene Painting Techniques & Materials	Racine Theatre Guild
2:00 - 4:00 p.m.	Meet the Companies	Racine Theatre Guild Tents
5:00 - 7:30 p.m.	Home Hosted Dinners - All Registrants & Companies	Various Locations
8:00 p.m.	Opening Night Ceremony	Racine Theatre Guild
9:30 p.m.	Reception - All Registrants & Companies. Sponsored by Palette Mask & Lyre Theatre, Antioch, IL	Racine Theatre Guild - Green Room

Thursday, June 23, 1994

7:30 - 11:00 a.m.	Workshops (See Schedule)	Gilmore Middle School & RTG
8:00 a.m. - 1:00 p.m.	Registration	Racine Theatre Guild
11:30 a.m. - 12:30 p.m.	Lunch - All Festival Registrants & Companies. Sponsored by ARA & Racine Theatre Guild	Racine Theatre Guild Tents
Competitive Session #1		
12:50 - 2:30 p.m.	Old Spain - Compania Vocacional del Real Coliseo del Escorial, SPAIN	Racine Theatre Guild
3:30 - 5:00 p.m.	The Three Cuckolds - Hva' Er Det Nu, De Hedder? DENMARK	Racine Theatre Guild
5:00 - 6:15 p.m.	Dinner All Festival Registrants Sponsored by Racine Children's Theatre	Racine Theatre Guild Tent
Competitive Session #2		
6:20 - 8:00 p.m.	Two - Stockport Garrick Theatre, ENGLAND	Racine Theatre Guild
9:00 - 10:30 p.m.	Le Tableau - Theatre des Quatres Saisons, FRANCE	Racine Theatre Guild
10:30 p.m.	Reception - All Registrants & Companies following final production Sponsored By Racine Theatre Guild	Green Room

Friday, June 24, 1994

7:30 - 11:00 a.m.	Workshops (See Schedule)	Gilmore Middle School & RTG
11:30 - 12:30 p.m.	Lunch - All Festival Registrants & Companies. Sponsored by Danny's Catering & RTG	Racine Theatre Guild Tents
Competitive Session #3		
12:50 - 2:30 p.m.	The Moisture - Scena Plastyczna, KUL, POLAND	Racine Theatre Guild

5:00 - 6:15 p.m. Dinner for all Festival Registrants & Companies. Sponsored by Innovative Daycare & Racine Theatre Guild Racine Theatre Guild Tent

Competitive Session #4

6:20 - 8:00 p.m. **The Host & The Guest**, Modi Nakhe, REPUBLIC OF GEORGIA Racine Theatre Guild

9:00 - 10:30 p.m. **The Donahue Sisters**, Aisling Productions, CANADA Racine Theatre Guild

10:30 p.m. Reception - All Registrants & Companies following final production Sponsored By Racine Theatre Guild Green Room

Saturday, June 25, 1994

Competitive Session #5

9:30 - 11:00 a.m. **Other People's Money** - Sioux Falls Community Playhouse, USA Racine Theatre Guild

11:30 - 1:00 p.m. **Gauche, The Cellist** - Theatre Group Ashibue, JAPAN Racine Theatre Guild

1:00 - 1:50 p.m. Lunch All Festival Registrants & Companies. Sponsored By The Olive Garden Racine Theatre Guild

Competitive Session #6

2:00 - 3:30 p.m. **The Dolls That Juana Makes Don't Have Eyes**, Compania Teatral Bottia & Cortes, COLOMBIA Racine Theatre Guild

4:00 - 5:30 p.m. **In The Jungle of Life** - Theater am Gymnasium Fellbach, GERMANY Racine Theatre Guild

6:00 p.m. Festival Awards and Closing Ceremonies Racine Theatre Guild

7:30 p.m. Winner's Showcase Performance 1st and 2nd Place Shows Racine Theatre Guild

8:00 p.m. AACT II Gala - Pre-Paid Event Racine Theatre Guild Tents

Sunday, June 26, 1994

9:00 am AACT II Farewell Brunch - Pre-Paid Event Racine Country Club

10:30 am AACT Annual Meeting To Be Determined

Departure of Companies as scheduled

Performance times are approximate. Many of the second performances in each session may start earlier than indicated.

Statement of Censorship

The American Association of Community Theatre supports a policy permitting the widest possible range of dramatic material to be performed in a festival of American community theatres. Performing companies are expected to exercise taste, good judgment and respect for the values of the host theatres.

Host theatres, if they have reason to believe a festival performance may be locally unacceptable, may notify their patrons in advance or publish a disclaimer, but in no case may the host refuse to allow the company to perform. Should the controlling body for the host theatre forbid said performance, the host group, with approval of the Festival Commission, shall provide an alternate performance space.

WORKSHOPS

Wednesday June 22, 1994

1:00 - 3:00 pm	Scene Painting Techniques & Materials Charles Erven, member of United Scenic Artists	Racine Theatre Guild
----------------	--	----------------------

Thursday, June 23, 1994

7:30 - 8:00 am	Early Bird Improvisational Theatre Mort Clark	Racine Theatre Guild
8:00 - 9:00 am	Session 1 - Acting & Directing American Style! Michael Fortner	Gilmore Middle School
9:00 - 10:00 am	Session 1 - Acting & Directing continued Session 2 - Stage Combat Lee Van Dyke - U.W. Parkside Session 3 - So, Your Theatre Wants to Host a Festival Jon Kerkhoff	Gilmore Middle School Gilmore Middle School Gilmore Middle School
10:00 - 11:00 am	Session 1 - AACT Theatre Insurance Plan Dan Castle Session 2 - Developing & Staging the Non-Traditional, Non-American Musical - Gustav-Adolf Frank	Gilmore Middle School Gilmore Middle School

Friday, June 24, 1994

7:30 - 8:00 am	Early Bird Improvisational Theatre Mort Clark	Racine Theatre Guild
8:00 - 10:00 am	Scene Painting - Techniques & Materials Charles Erven	Racine Theatre Guild
8:00 - 9:00 am	Session 1 - Government Support of the Arts American & International Panel Session 2 - The Comedia dell' Arte Hva' Er Det Nu, De Hedder? Session 3 - Oriental Dance and Movement Dr. Chua Soo Pong	Gilmore Middle School Gilmore Middle School Gilmore Middle School
9:00 - 10:00 am	Session 1 - Attracting and Retaining Theatre Volunteers Twink Lynch Session 2 - AACT Theatre Insurance Plan Dan Castle Session 3 - Oriental Dance and Movement, continued	Gilmore Middle School Gilmore Middle School Gilmore Middle School
10:00 - 11:00 am	Session 1 - Stage Combat Lee Van Dyke - U.W. Parkside Session 2 - Media Matters Brid McBride Session 3 - The Graying of the American Community Theatre Bruce Tinker	Gilmore Middle School Gilmore Middle School Gilmore Middle School

OPENING CEREMONIES

THE BEAR CLAN DANCERS DIRECTED BY GERALD CLEVELAND

Mr. Cleveland, a member of the Winnebago Tribe, which is comprised of 14 clans, belongs to the Bear Clan, hence the name "Bear Clan Dancers." He was taught to dance by his parents when he was very young. Cleveland's parents also taught him to do beading and construct costumes and dance regalia. Today, he and his wife, Iris make all the costumes and beadwork for the dance company. Complying with tradition, each costume is treated with utmost respect and care. The feathers worn by the dancers are from golden eagles. A dancer wearing eagle feathers must earn each one by having done something heroic or worthy. One who wears eagle feathers "must be a warrior", says Cleveland. Long fringes on the costumes represent long prairie grasses. He reports a good "grass dancer" moves in a way that keeps the fringe flowing and smooth, similar to the way wind moves the grasses. Cleveland emphasizes "smooth is always the hallmark of a good Native American dancer. Only the contemporary dance of the Fancy Dancers is allowed to be wild and unpredictable."

Cleveland is very selective in choosing those who will dance with his group. He has traveled throughout the United States to watch specific dancers. Every member of the Bear Clan Dancers is rated a World Class Dancer and takes their heritage seriously and lives by traditional standards.

Contact Person: Gerald Cleveland
2012D McArthur Road
Waukesha, WI 53188 USA

"OUTSTANDING"

— STAGE
DIRECTIONS
magazine

FULL HOUSE

The Definitive Guide
For Successfully
Promoting
School and
Community Theater

by George E. Chartier



- ◆ Successful news releases
- ◆ Secrets of great photos
- ◆ Powerful poster design
- ◆ Working with reviewers
- ◆ Staging publicity stunts
- ◆ Building group identity

JAM-PACKED with practical advice and creative approaches to publicity that captures attention and brings in audiences, here is the all-purpose guide book every theater needs!

Jumbo 8 1/2 x 11" • 240 pages • 150 illustrations

ORDER TODAY! Send \$24.95 plus \$2.50 shipping & handling (1 book, \$2.50; 2 or more books, \$1.50 each; outside USA, add \$1.00) to: Dramatic Concepts Publishing, P.O. Box 532, Mansfield Center, CT 06250



LUBLIN, POLAND

THE MOISTURE

CONCEIVED AND DIRECTED BY
LESZEK MADZIK



Scena Plastyczna KUL

Scena Plastyczna KUL of the Catholic University of Lublin is a theatrical group that was founded by Leszek Madzik in 1969. By attaching great importance to visual and, in particular, sculptural stage expressions, Scena Plastyczna KUL has developed a unique theatrical discipline. With intensified effects, Scena Plastyczna KUL has composed a minimalistic and striking stage language that speaks to everyone no matter to what history or culture they belong. Known throughout the world, they have performed in many countries including England, Russia, Egypt, France and Germany.

The Scena Plastyczna KUL is by its nature a philosophical theatre. The plot of Leszek's spectacles are related to the fundamental emotions experienced at various stages of human life as well as to the entire human existence. Misery, love, death, nostalgia, desire, fear, sensual joy or horror determine the scale of existence, the level of reflection eager to get the substance of life and the measure of spiritually contained in it. Catharsis is mixed with tragedy, emotion with anxiety, virtue with evil. The main elements constituting the substance of this theatre are space, rhythm and atmosphere. All these elements are part of human existence.

The theatrical means, chosen by Madzik to show his vision of the truth, is the artistic narration, supported by sounds. The drama of music has always given substance to the movement of visions. In all his spectacles, the power of music was harmonized with the intensity of light, which created forms and expression. From the theatrical point of view, Madzik is inspired by the dramaturgy of Gordon Craig whose creative activity in Europe extends for the first half of the 20th century. One of the characteristic features in the "theatre" without actors or rather "impersonal actors" serving as accessories. Madzik relinquishes the word, seeking very simple visual media aiming at reaching the essence of life itself.

Cast

Cezary Figura
Jaroslaw Figura
Darisz Golinski
Ewa Karolak
Edyta Kruk
Agnieszka Twerd
Marcin Pastwa

Production Staff

Artistic Director	Leszek Madzik
Company Manager	Piotr Zielinski
Chief Technician	Jaroslaw Figura
Sound & Light Technician	Waldemar Gasior



Contact Person: Artur Przystupa, ul. Ogrodkowa 3/74,
Lublin, POLAND

The DRAMA BOOK SHOP, Inc.



Specializing in Published Plays and Books on Every Aspect of Film, T.V. and the Performing Arts.
Phone and Mail Orders Welcome.

Incorporated 1923

723 Seventh Ave., New York, NY
10019 Phone (212) 944-0595

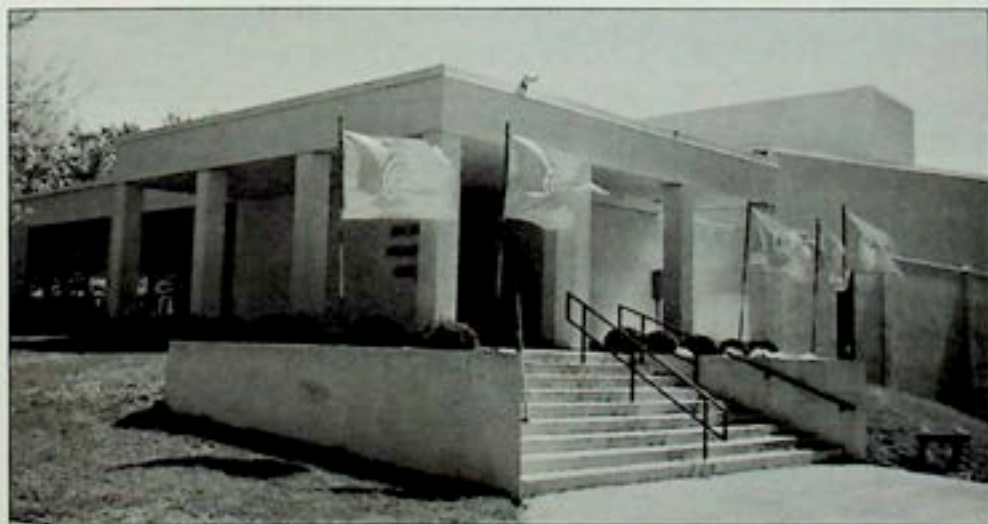

Racine Theatre Guild, Incorporated
2519 Northwestern Avenue
Racine, Wisconsin 53404, USA

Founded in 1937, the Racine Theatre Guild is recognized both nationally and internationally having hosted state, regional, and national AACT-Fests and international theater companies. The 405-seat thrust stage theater, that opened in 1976, features a well equipped shop, excellent sound and lighting systems and is totally air conditioned.

SOUND OFF!

Unbelievable low discount prices are our trademark! Impeccable sound is our business! Lighting too!



- Microphones
- Wireless Microphones
- Amplifiers
- Speakers
- Signal Processing
- Tape
- CD Players
- Recorders
- Mixers
- AutoCue
- Fog Machines
- GEL
- Turntables
- Intercoms
- Headphones
- Parts
- Video
- Lighting



1-800-356-5844

Over 350 Product Lines • Audio • Video • Lights

FULL COMPASS

Consultation: 608/271-1100
5618 Odana Road
Madison, Wisconsin 53719 • USA

RACINE THEATRE GUILD BOARD OF DIRECTORS

Ronald G. Halvorsen - President
 Geoffrey R. Greeley - Vice-President
 Mary Waid - Recording Secretary
 John Andreoli - Treasurer
 Sandy Berezowitz - Corresponding Secretary
 Pat Arena
 Sherry Babicky
 Dave Brantingham
 Alice Anne Conner
 Kevin Hlavka
 Janice Lutz
 Terry Mellor
 Norman C. McPhee Ex-Officio
 Karen O'Donnell
 Alan Reid
 Jerry Rannow
 Colleen Romsa
 Russ Stetler

Theatrical Kits Are The Way To Go!

... and Bob Kelly's theatrical makeup kits fill all your makeup needs and at remarkably low prices. Go for it!



The Mirage Makeup Kit \$28.95*

NOT SHOWN: The Creme Stick Makeup Kit-\$32.95 • The Littlest Kelly Kit-\$18.95

Bob Kelly's NEW Videotape Offer for a complete set of 7!



Here's the deal:

Although you can order the individual cassettes (and none is under 1 hr - 15 min.) for \$20 each, you can get the complete set for only

\$105*

They are:

INSTRUCTIONAL THEATRICAL MAKEUP—TAPE #1
 INSTRUCTIONAL THEATRICAL MAKEUP—TAPE #2
 THE BOB KELLY HALLOWEEN VIDEOTAPE
 THE BOB KELLY CLOWN VIDEOTAPE
 THE BOB KELLY ANIMAL FACES VIDEOTAPE
 PROSTHETICS INSTRUCTIONAL VIDEOTAPE—TAPE #1
 PROSTHETICS INSTRUCTIONAL VIDEOTAPE—TAPE #2

For further information about the above 7 send for our catalog and order form.
 *Plus \$2.50 per kit, \$2.75 per tape and \$5.00 per tape set for Shipping & Handling/
 West Coast add \$4.00 per kit, \$3.00 per tape and \$7.00 per tape set. No. C.O.D.

BOB KELLY COSMETICS, INC.
 151 WEST 46th STREET • NEW YORK, N.Y. 10036 • (212) 819-0030

STRAND LIGHTING and MID-WEST SCENIC are proud to be sponsors of the 2nd International AACT-Fest.

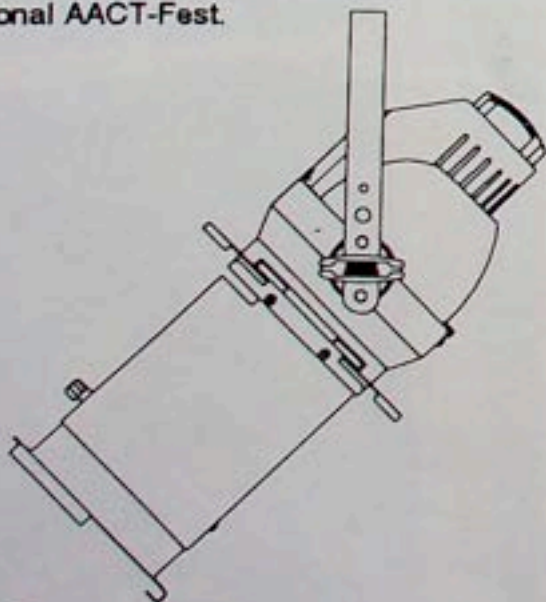

LEKO • The Tradition Continues

 Strand
Lighting

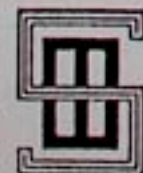

midwest scenic & stage
 equipment company, Ltd.
 224 west bruce street
 milwaukee, wisconsin 53204

AACT Board of Directors 1993-94

Ginny Winsor, President
Omaha Community Playhouse
6915 Cass Street
Omaha, NE 68132

John Viars, Past President
Des Moines Playhouse
831 42nd Street
Des Moines, IA 50312

Ron Ziegler, Exec. Vice President
Sioux Falls Community Playhouse
P.O. Box 600
Sioux Falls, SD 57101

**Julie Angelo, Vice President -
Planning & Development**
Denton Community Theatre
P.O. Box 1931
Denton, TX 76202

**Jon Kerhoff, Vice President -
Festivals**
Omaha Community Playhouse
13057 West Canter Road, Ste. 1
Omaha, NE 68144

**Jack Phillips, Vice President -
Public Relations**
Spokane Civic Theatre
P.O. Box 5222
Spokane, WA 99205

**JoAnne Nissen, Vice President -
Membership**
Racine Theatre Guild
3623 Maryland Avenue
Racine, WI 53405

Mary Doveton, Treasurer
Lawrence Community Theatre
2130 Owens Lane
Lawrence, KS 66046

Frank Peot, Secretary
Wisconsin Theatre Association
1747 Pennsylvania Avenue
Sun Prairie, WI 53590

Don Bachmann, Member-at Large
Theatre Midland
2000 W. Wadley
Midland, TX 79705

Pat Butcher, Member-at-Large
Concord Players
70 Elm Street
Concord, MA 01742

Dick Engbers, Member-at-Large
Evansville Civic Theatre
P.O. Box 804
Evansville, IN 47705

**Rod McCullough, Member-at-
Large**
Lincoln Community Playhouse
2500 S. 56th
Lincoln, NE 68506

**Shirley Cockrell, Member-at-
Large**
Oneida Area Little Theatre
526 Elizabeth Street
Oneida, NY 13421

Mary Britt, Member-at-Large
Ocala Civic Theatre
P.O. Box 2132

Bruce Tinker, Member-at-Large
Fargo Moorhead Community
Theatre
626 S. University Drive
Fargo, ND 58103

Norm Small, Member-at-Large
Theatre Winter Haven
405 L.K. Ned Road
Winter Haven, FL 33884

Jeanne Stein, Member-at-Large
Los Alamos Little Theatre
167 Andanada
Los Alamos, NM 87544

AACT Regional Representatives 1993-94

REGION 1 (CT, ME, MA, NH, RI, VT)
Harriet Fridman
Carpenter Square & Lyric Theatre
267 Bishops Forest
Waltham, MA 02154

REGION 2 (DE, DC, MD, NJ, NY, PA)
Mort Clark
Westchester Community College
14 Lawrence Drive
N. White Plains, NY 10603

REGION 3 (IL, IN, MI, OH, WI)
Bob Kafka
Village Playhouse
2418 North 11th Street No. 2
Wauwatosa, WI 53226

**REGION 4 (AL, FL, GA, KA, MS,
NC, PR, SC, TN, VA, VI WV)**
Murray Chase
P.O. Box 127
Corinth, MS 38834

**REGION 5 (IA, KS, MN, MO, NE,
ND,SD)**
John Harper
Iowa City Community Theatre
1310 Bristol Drive
Iowa City, IA 52245

REGION 6 (AR, LA, NM, OK, TX)
Paula Sharum
Ft. Smith Little Theatre
1 Riverlyn Drive
Ft. Smith, AR 72903

REGION 7 (CO, ID, MT, UT, WY)
Richard Kuebler
Prairie Players
116 S. 3rd Avenue #7
Sterling, CO 80751

REGION 8 (AZ, CA, HI, NV)
Kay Smith
Tokay Players
7060 Bridgeport Circle
Stockton, CA 95207

REGION 9 (AK, OR, WA)
Joan Miller
San Juan Community Theatre
2500 Douglas Road #47
Friday Harbor, WA 98250

“All the world’s a stage.”

William Shakespeare

**SC Johnson
wax**
Racine, Wisconsin

